

NOT FOR USE WHERE FAILURE CREATES A HAZARD TO HUMAN HEALTH OR SAFETY. ALL PRODUCTS ARE SUBJECT TO THIS FULL DISCLAIMER: <http://www.ihconnectors.com/disclaimer.html>

FOR FURTHER INFORMATION ON THE PROPER USE OF THIS PRODUCT IN SPECIFIC APPLICATIONS SEE <http://www.ihconnectors.com/GuideToFlexFlexibleFineStrandedWireCableMechanicalLugsFAQ.html>  
<http://www.ihconnectors.com/Technical-Data-Installation.htm>

IHI UL/CSA Installation Guide to Drill or Enlarge Mounting Holes:  
<https://lugsdirect.com/PDF%20Documents/IHI-MTG-HOLE-FIELD-MODS-UL&CSA-CERTIFICATIONS.pdf>

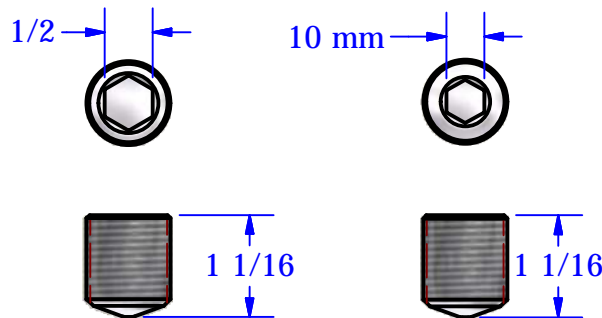

STD. SCREW #14141

OPTIONAL METRIC SCREW ADD "-M" TO PN. I.E. S500-41-63-M

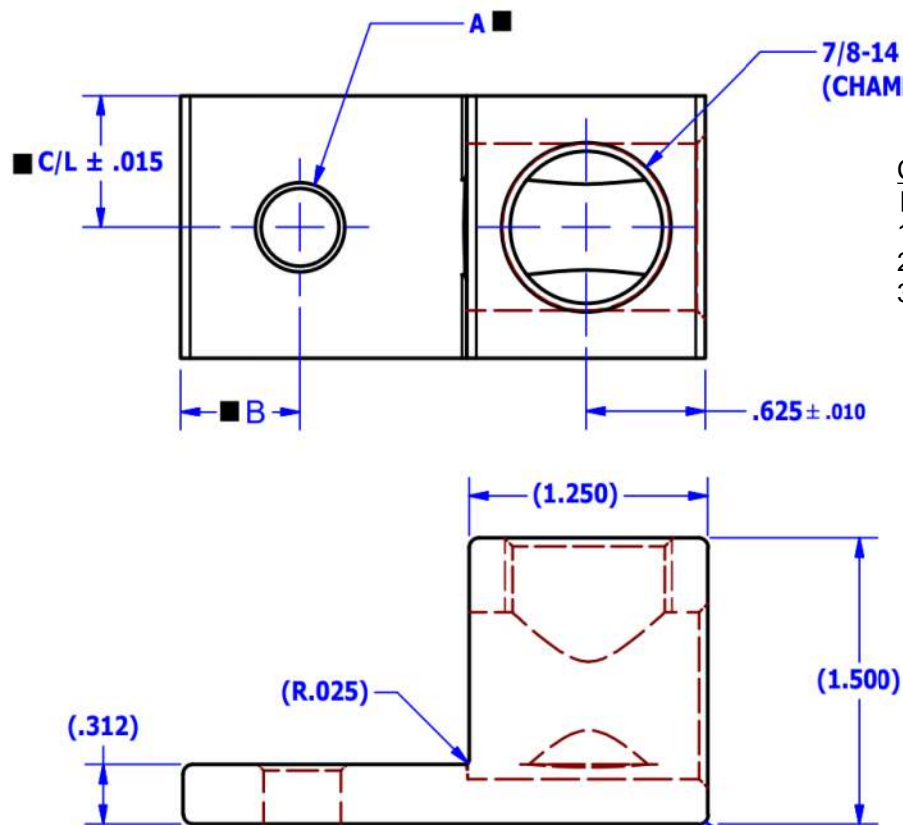

Cat No. S500 Style No. 1

- Drill, Enlarge, or Modify Mounting Holes
- 1) Increase hole(s) dia. to 5/8 bolt
- 2) Move location of mounting hole(s)
- 3) If buying blank lug, put custom hole(s) in.

Ø.875 (CHAMFER .045 X 45°)

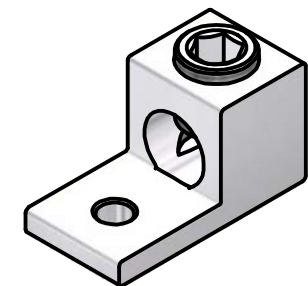
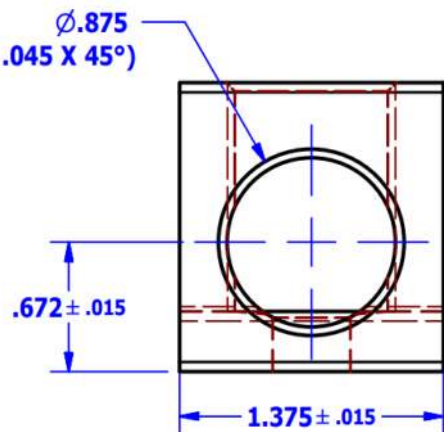

PARTS MARKED:  
 S500 IHI LOGO  
 500 KCMIL-4 UL LOGO  
 CU9AL CSA LOGO

FLEX WIRE 350 KCMIL - 4 AWG

PART BODY	BOLT	'A'	'B'
S500-41-63	3/8*	.410±.010	.625±.010
S500-41-107	3/8*	.410±.010	1.067±.010
S500-53-63	1/2	.530±.010	.625±.010

FOR VOLUME OEM APPLICATIONS, CUSTOM MOUNTING HOLE ARRANGEMENTS MAY BE AVAILABLE. MINIMUM LOT SIZES, NCNR ORDERS, AND OTHER CONDITIONS MAY APPLY.

\*OR M10 BOLT

THIS DRAWING AND DESIGN ARE THE PROPERTY OF INTERNATIONAL HYDRAULICS, INC., CLEVELAND, OHIO, AND MAY NOT BE DUPLICATED, USED FOR THE BASIS OF DESIGN OR MANUFACTURE WITHOUT THE WRITTEN PERMISSION OF INTERNATIONAL HYDRAULICS, INC., CLEVELAND, OHIO.		INTERNATIONAL HYDRAULICS, INC.			
GENERAL TOLERANCES ±.015 (±0,038)		TITLE: S500-XX-XX			
MATERIAL: AL		4 AWG - 500 KCMIL WIRES			
SIZE: A	DRAWN BY: DJH	DWG NO.:	S500-XX-XX (SALES)		REV: 0
FINISH: TIN PLATE ON AL	DATE: 6/5/2015	IHI CONNECTORS			